

CCE 6101 | CCE 6201 | CCE 6301 CHILLERS 1100–2400 W

- stand-alone chiller
- fluid cooling with water, water/glycol mixtures
- steel housing with thick powder coating
- robust industry standard with preassembled eyebolts
- reliable easy to read level indication
- mounting on top of the enclosure is possible
- integration of project-specific additional components is possible on request
- separate cooling circuit and hydraulic circuit
- equipped with a programmable control module that allows small hystereses of the temperature of the cooling medium



PRODUCT	CCE 6101 S	CCE 6201 S	CCE 6301 S	UNIT
ARTICLE NO.	42130115003	42130175003	42130245005	
DATA				
Rated voltage	AC 50 60 230 1~			Hz ±1 % V ±10 %
Cooling capacity (with pump) W18/A32	1.1	1.7	2.4	kW
Flow rate (pump) ¹	7.5			l/min
Pump pressure	3.5			bar
Ambient temperature	+15 ... +45 +59 ... +113			°C F
Medium	water/glycol – 80/20			
Medium temperature (outlet)	+13 ... +35 +55 ... +95; factory setting +18 +64			°C F
Target value tolerance	±2			K
Refrigerant R134a	650			g
Max power consumption	1.2 1.4	1.3 1.5	1.5 1.7	kW
Max current consumption	7 7.5	6.5 6.5	7.5 8	A
Starting current	40 49	40 49	45 54	
Control voltage	AC 230			V
Pre fuse T	15			A
Airflow ¹ external	1300			m ³ /h
Tank volume	10			l
Connections (medium) IG	1/2"			BSP
Noise level @ 50 Hz (EN ISO 3741)	< 62			dB (A)
Weight (without packaging)	67		72	kg
Protection system according to EN 60529	IP 54			
Colour	RAL 7035 different colours available on request			

For additional models, options, voltages and accessories visit www.pfannenber.com or contact us directly.

¹ performance data based on 50 Hz operation



COOLING CAPACITY PERFORMANCE CURVES

CCE 6101 S (50 Hz)¹

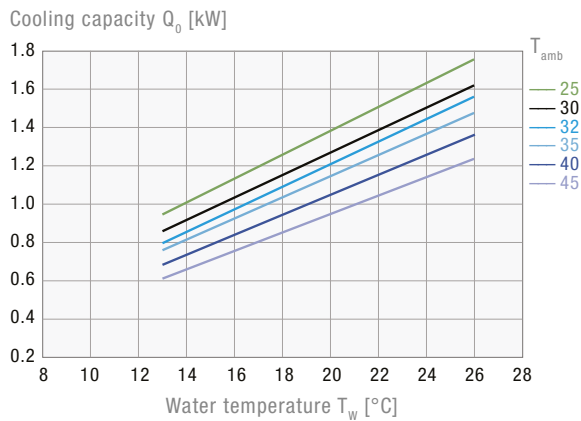

CCE 6201 S (50 Hz)¹

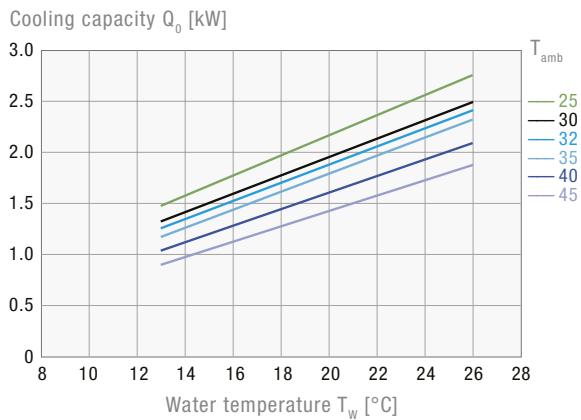

CCE 6301 S (50 Hz)¹

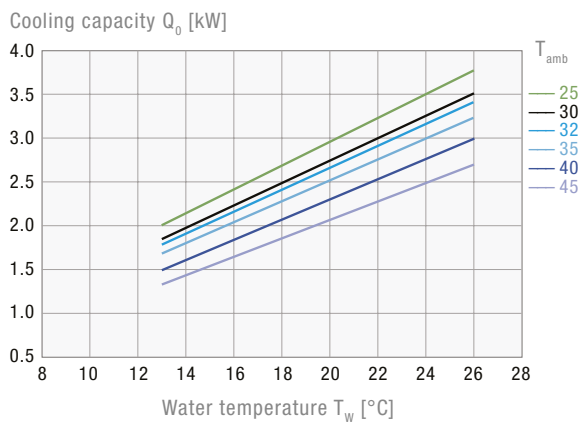

DIMENSIONS

mm	CCE 6101 6201 6301
X	600
Y	571,5 ²
Z	495
A	574
B	435,7

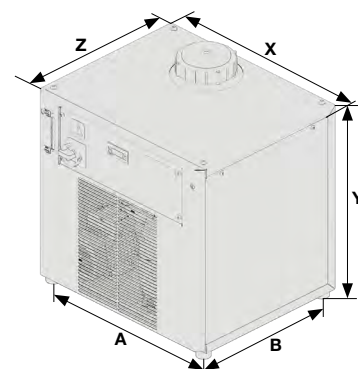

¹ the performance curves for the 60 Hz version can be obtained from your Pfannenberg advisor or at www.pfannenberg.com
² with eye bolts